

Gobo 高宝

感受高宝·舒适无限

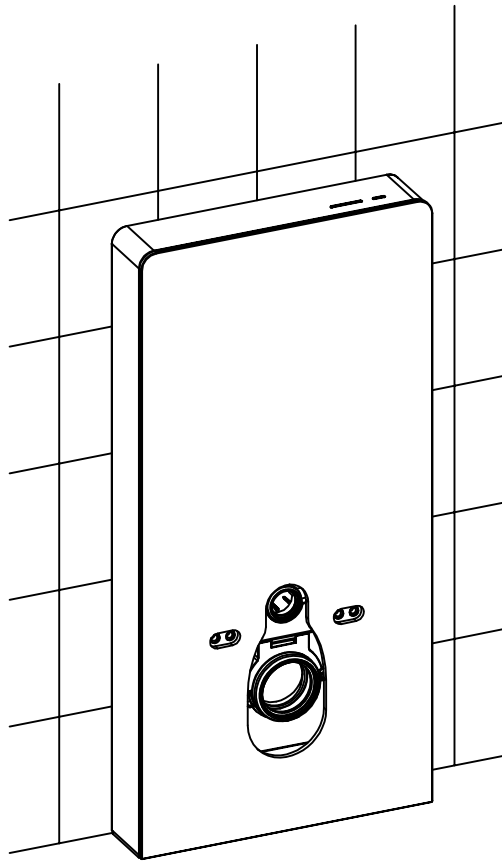

型 号 : GC-SX05-W/GC-SX05-B

- 感谢您对本公司产品的厚爱！安装前，请先阅读此说明书，阅读后请妥善保管，以备日后查用
- 本手册的最终解释权归本公司所有，如有变更，恕不另行通知

目 录

Content

材料清单	2
Item List	
技术规格	4
Technical Specifications	
技术图纸和进水、排污连接建议	5
Technical drawing, inlet system & drainage system	
安装	6
Cistern installation	
日常保养与拆装	16
Maintenance & daily care	

材料清单

Item List

零件列表 Item list	零件名称 Names	规格 Specification	数量 Quantity	零件列表 Item List	零件名称 Names	规格 Specifications	数量 Quantity
	橡胶转接套 rubber seal	Ø110	1		膨胀头 expansion nut	SX10 Ø6-8	2
	排水直管 straight flush pipe		1		螺钉 screw	ST6.8*67	2
	排水接套 flush pipe		1		垫片 washer	Ø22*2.0	2
	排水移位管 eccentric pipe		1		螺杆 M12 bolt		2
	转接头橡胶 rubber seal		1		装饰帽 decorative cap		2
	透明气管 transparent air hose	transparent L:350mm	1		六角螺母 M12 nut		2
	蓝色气管 blue air hose	blue L:300mm	1		大垫片 big washer	Ø32.5*2.5	2
	透明气管 transparent air hose	transparent L:650mm	1		橡胶柱套 rubber sleeve		2
	冲水直管 flush pipe		1		装饰帽底座 decorative cap base		2
	冲水密封套 rubber seal on above pipe	Ø60	1		钢质膨胀螺栓		2
	膨胀头 expansion nut	8*40	2		垫片 washer	Ø11*1.2	2
	螺钉 screw	ST4.8*45	2		马桶缓冲垫 toilet mat		1

材料清单

Item list

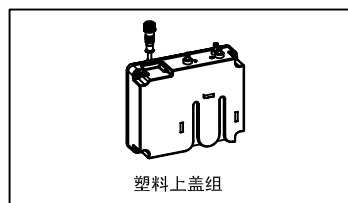
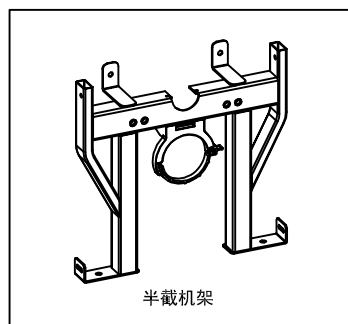
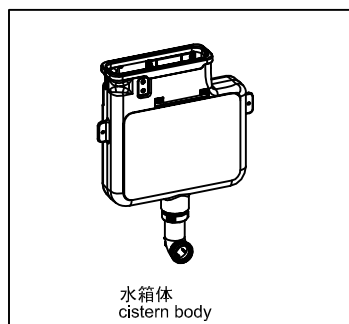
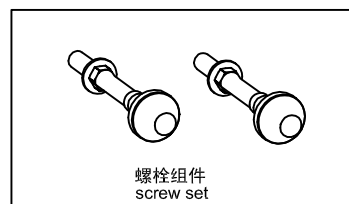
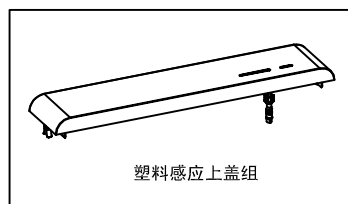
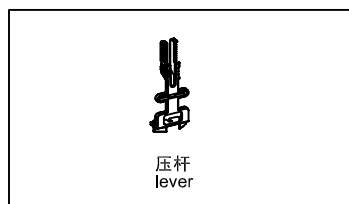
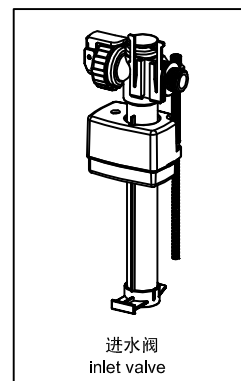
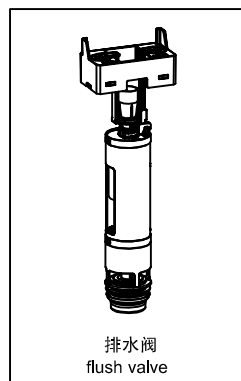
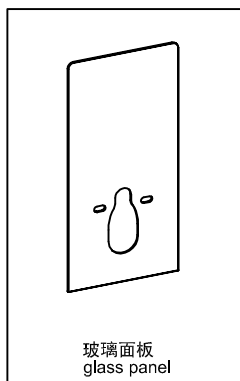
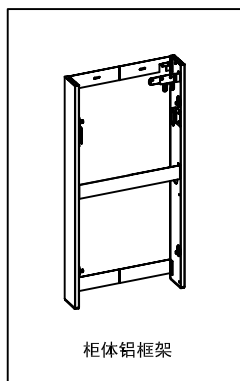

技术规格

Technical Specification

名称 name	壁挂感应式柜体水箱 Automatic Infrared cabinet cistern for wall-hung WC	
型号 model	GC-SX05-W/GC-SX05-B	
技 术 规 格 Technical Specification	额定电压 rated voltage	220V AC, 50HZ
	环境温度 ambient temperature	3~40°C
	供水压力 water supply pressure	0.07~0.75MPa
	供水温度 water supply temperature	4~35°C
	防水等级 waterproof rating	IPX4
	尺寸 dimension	1003.5mm X 483mm X 108mm

技术图纸和进水、排污连接建议 Technical drawing, inlet system & drainage system

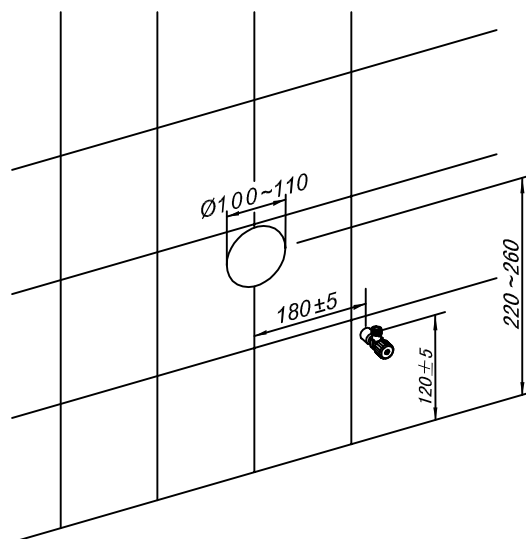
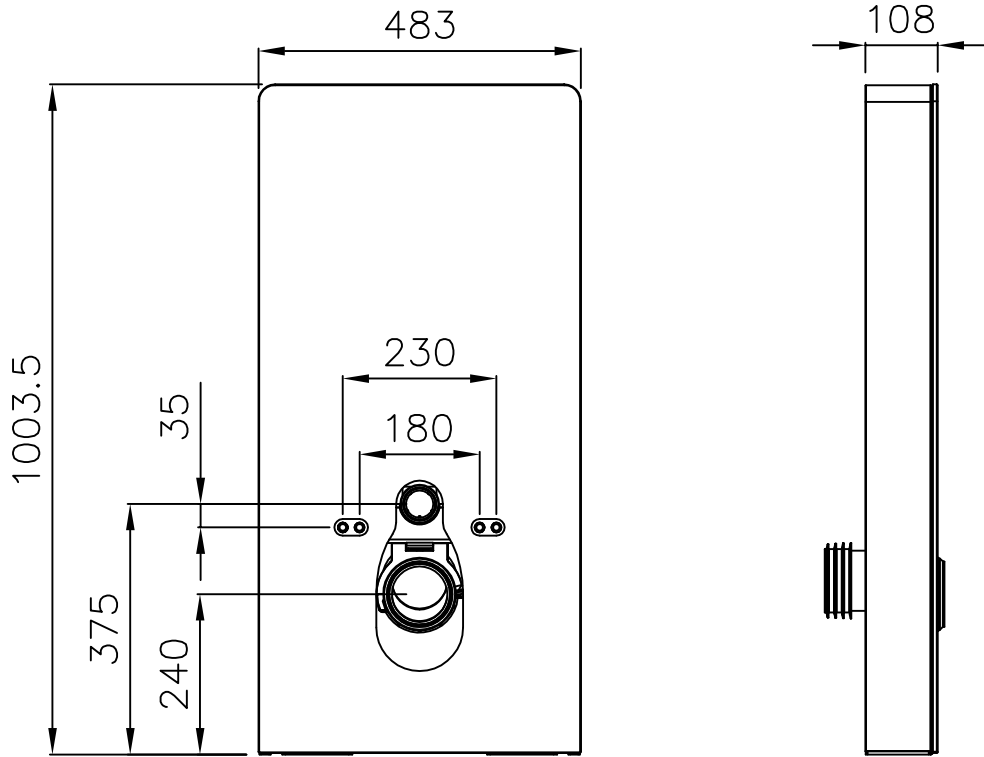

1

安装过程 Cistern installation

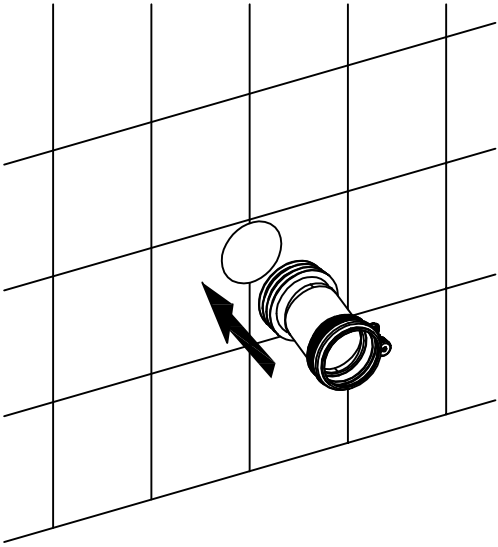

把排污管插入到墙上的排污孔
insert the drainage pipe into
the drainage hole on the wall

2

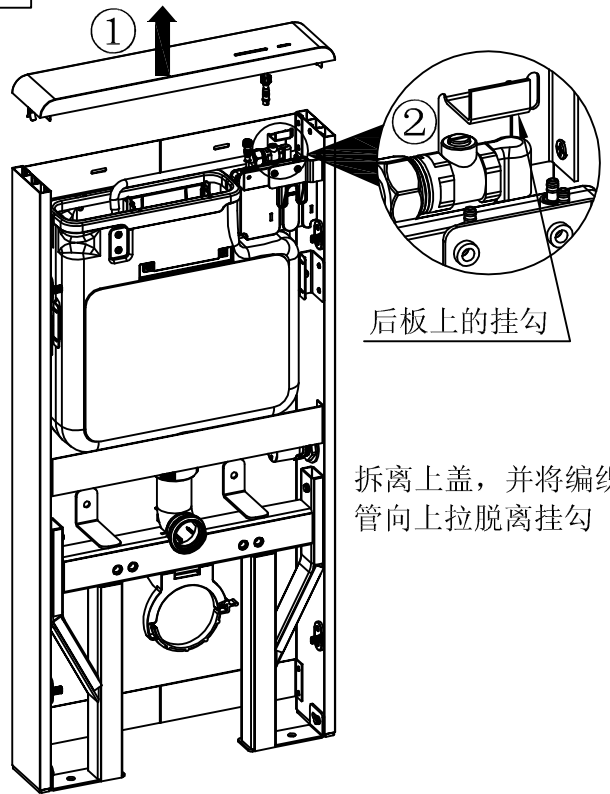

3

将柜体紧靠墙壁，同时旋转排污管以
适应排水管夹

lean the whole cistern to the
wall and align the flush pipe
position with the buckle

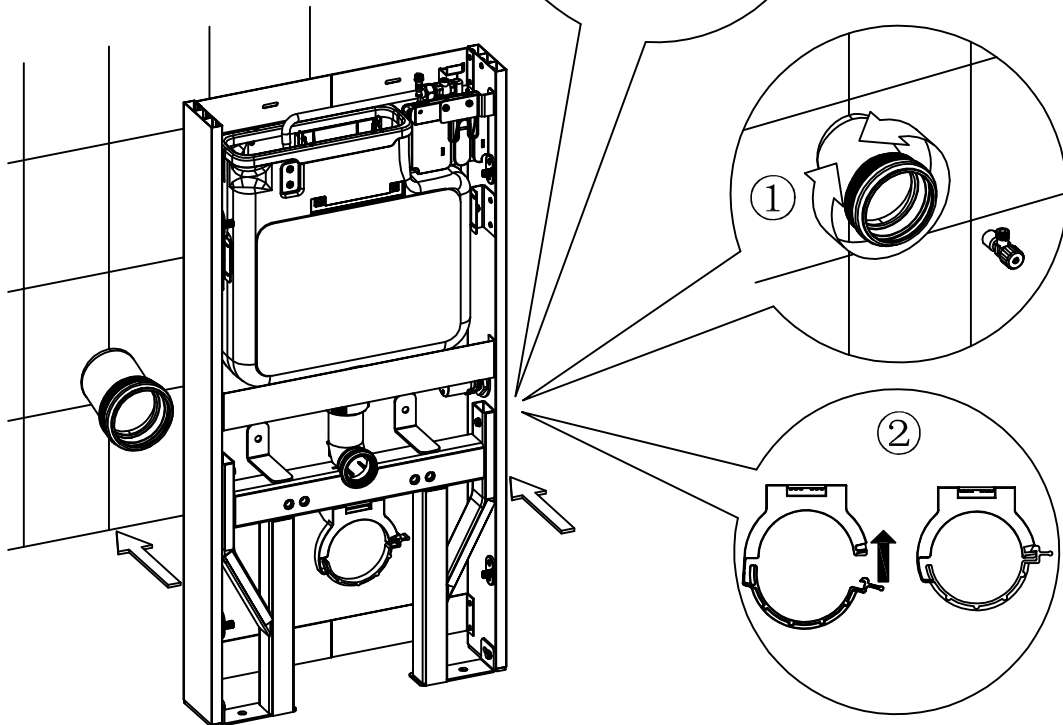

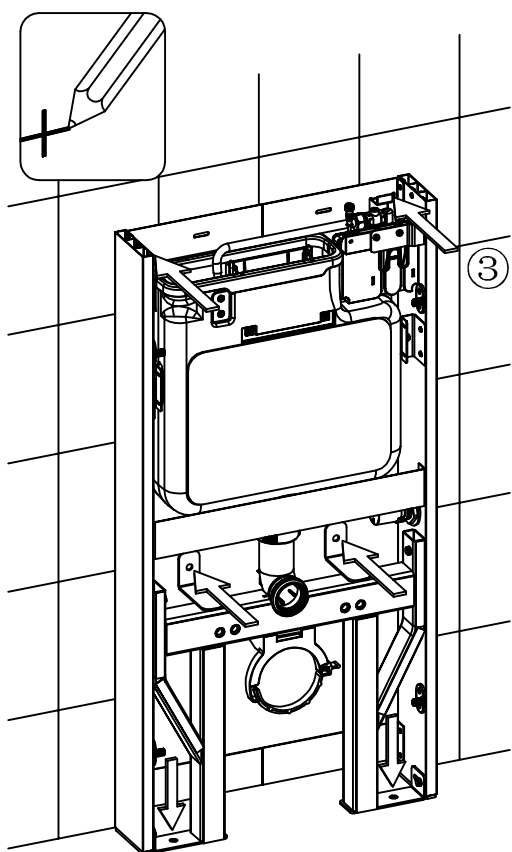

如箭头所示，在墙面相应位置标记4个点，在地面标记2个点

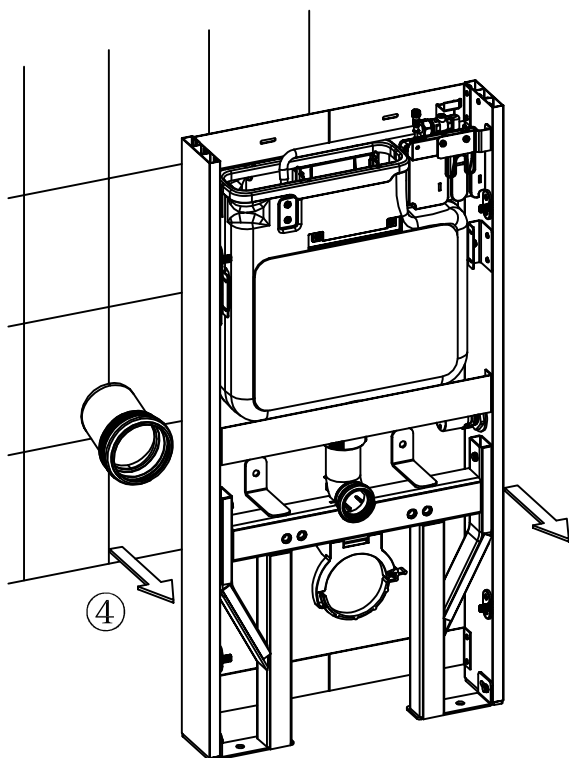

移开柜体
then move off cistern first

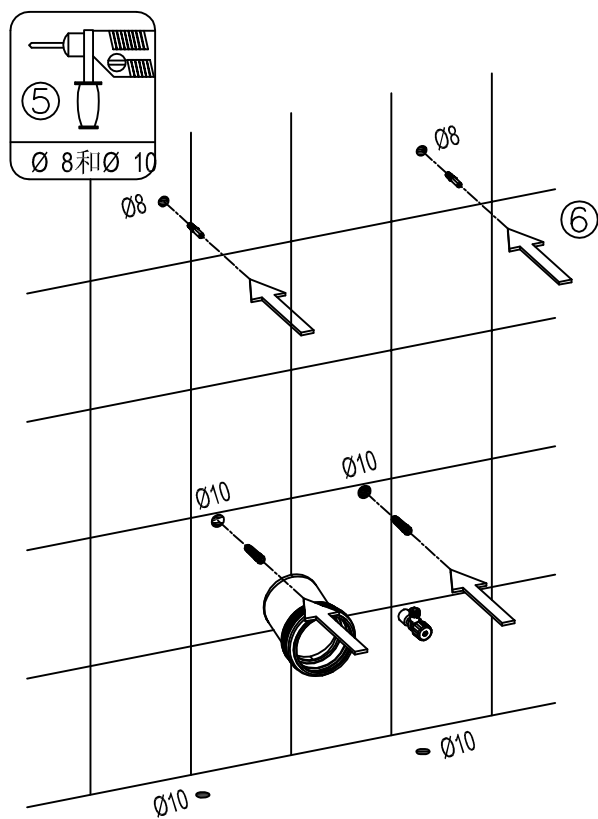

在标记点上钻孔（钻孔深度要大于膨胀头长度，孔径如图所示），并压入相应大小的塑料膨胀头

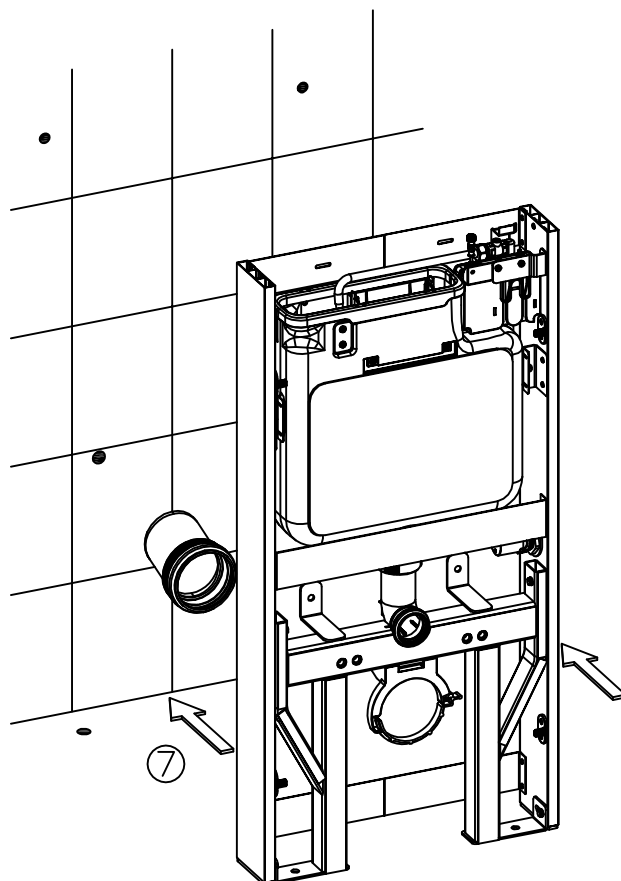

把柜体重新靠回到墙上的正确位置

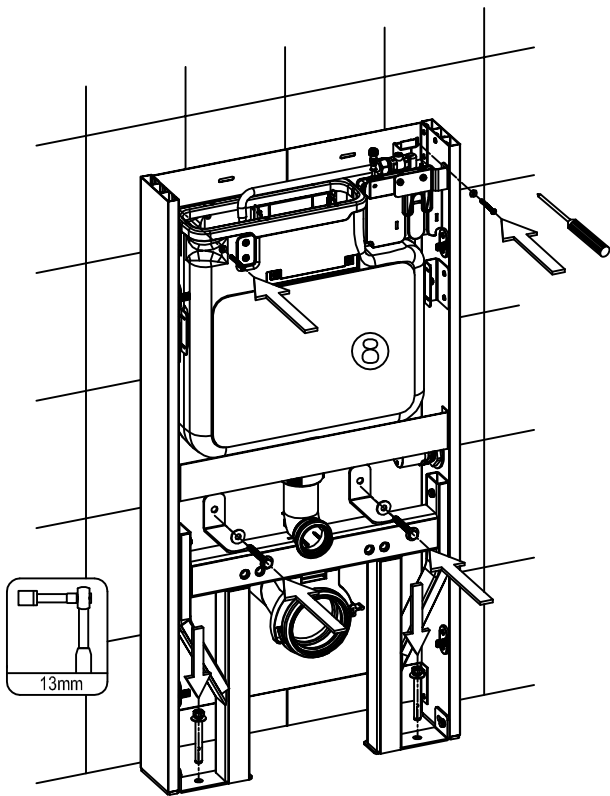

将相应大小的螺钉锁进墙面塑料膨胀头，并将钢质膨胀螺栓锁入地脚

4

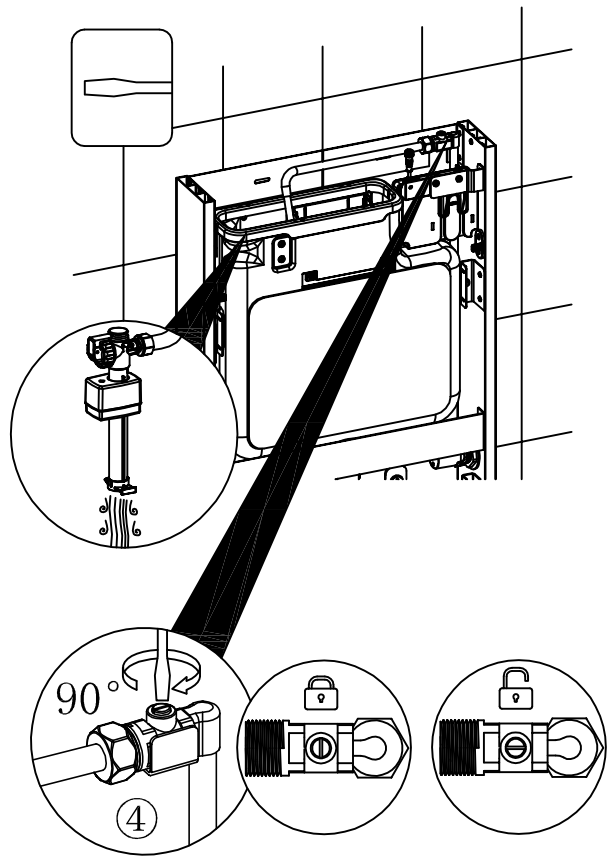

打开编织管上的阀门，并观察水箱是否正常进水，并确认编织管和水箱无漏水现象

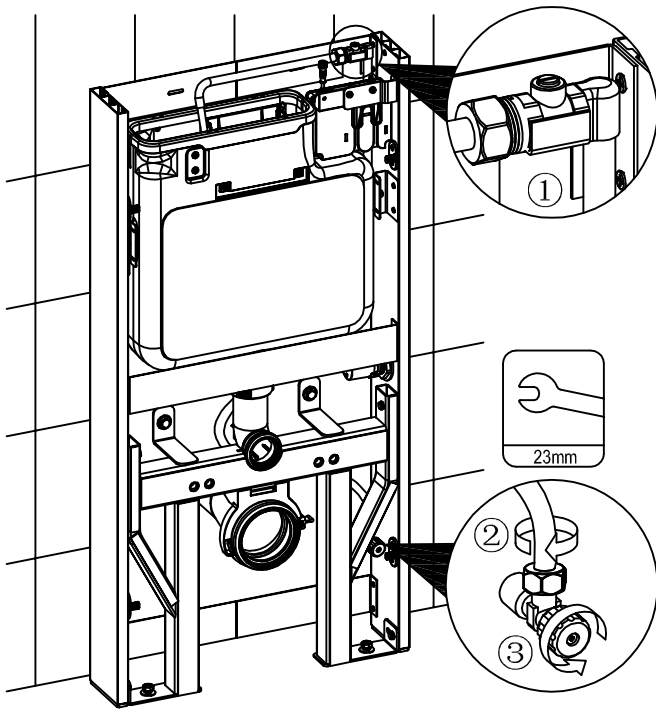

将编织管重新扣入后板上的挂勾，再将编织管和墙上的角阀连接起来

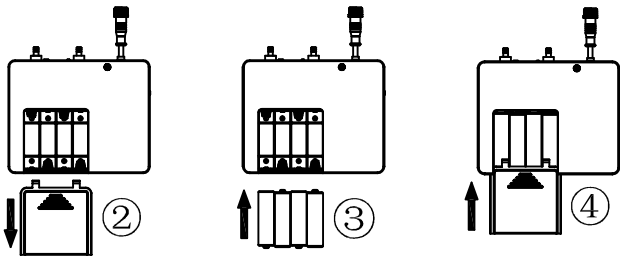
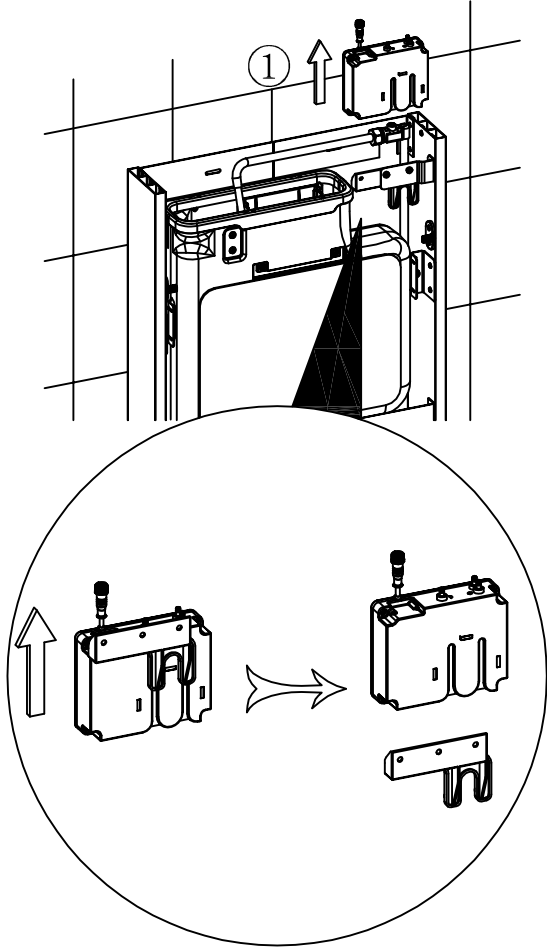

注意：需用碱性电池，且不能新旧混用
Mark: All batteries should be AAA batteries, and please do not mix old and new batteries when using.

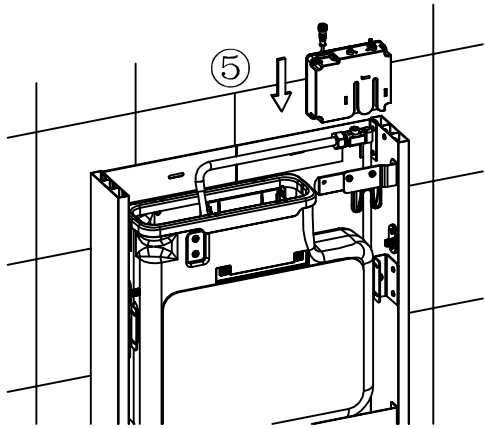

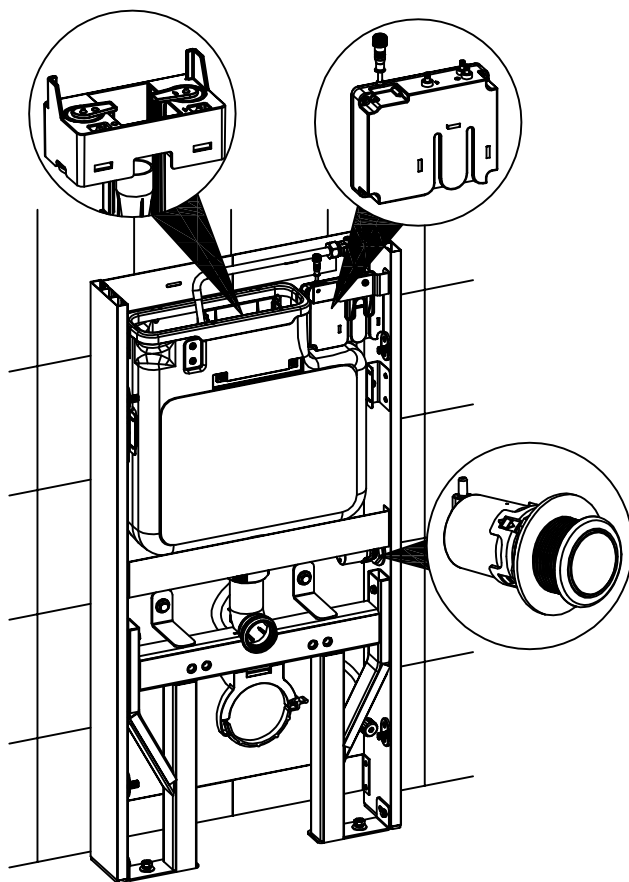

⑥

蓝色气管
blue air hose

透明气管
transparent air hose

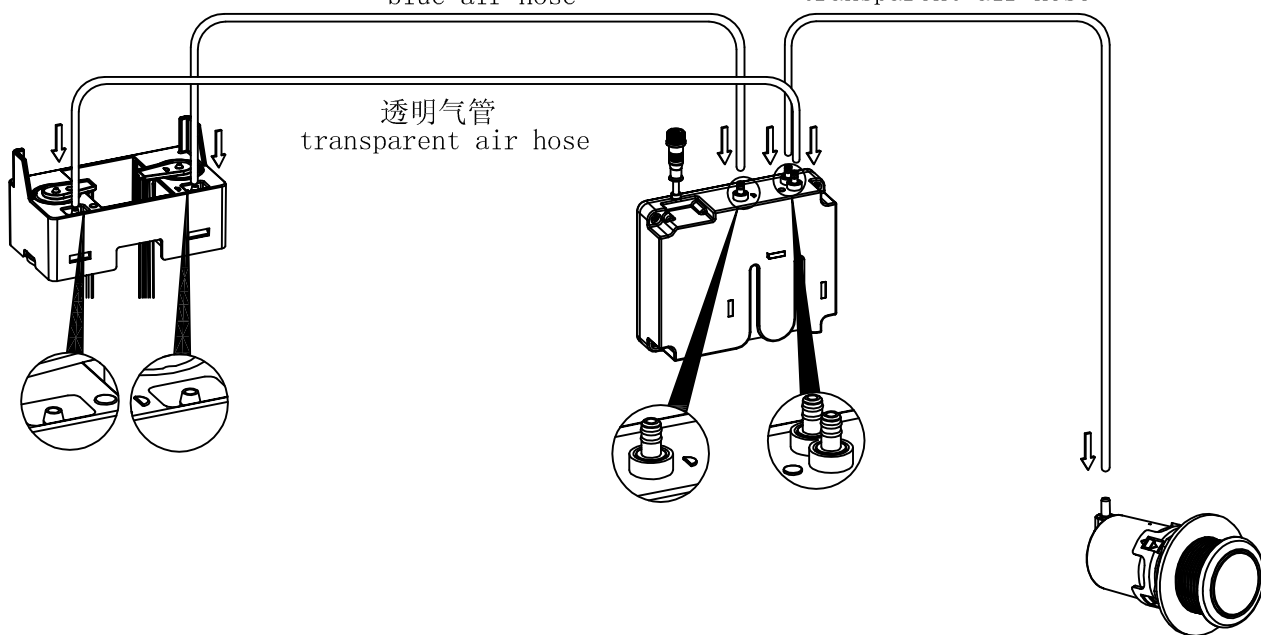

透明气管
transparent air hose

6

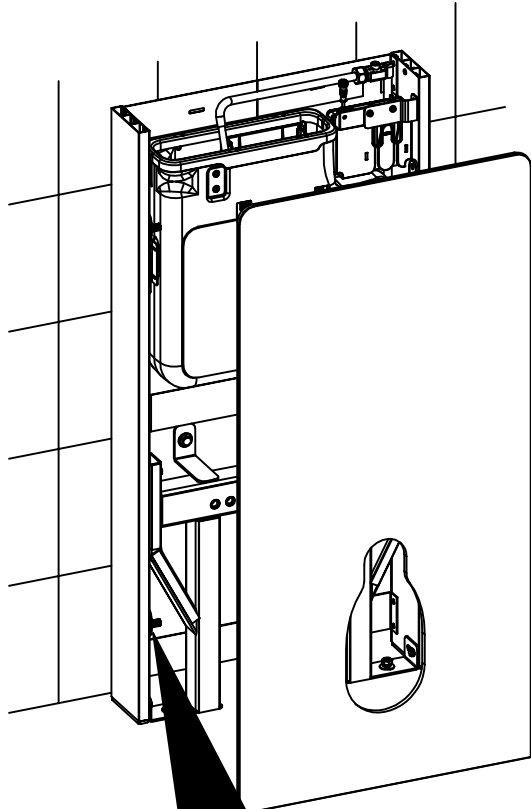

黏在玻璃上的铁片

(4pcs) support buckle stuck on the glass (4pcs)

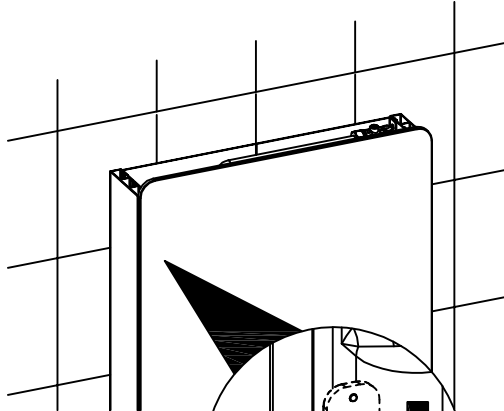
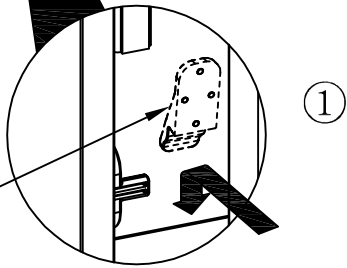

②

把玻璃安装到铝框架上，再把铁片向下推，直到铁片勾住铝框架上的挂件。

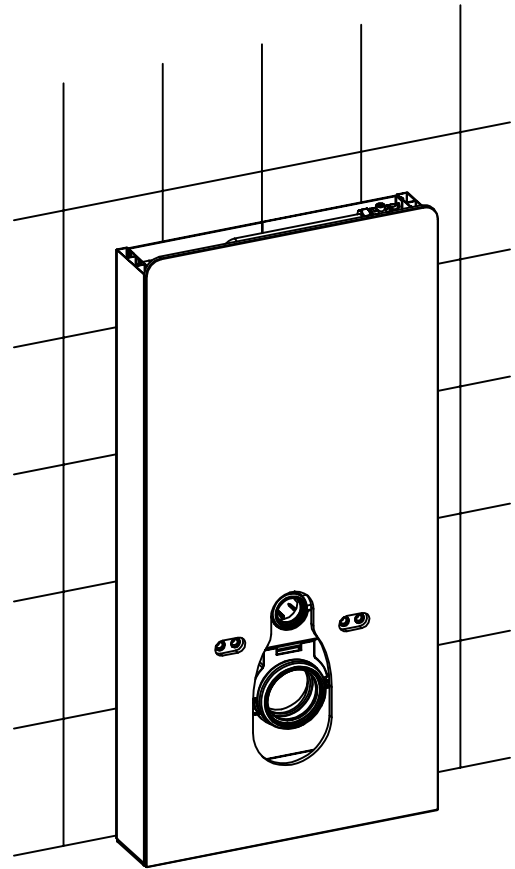

7

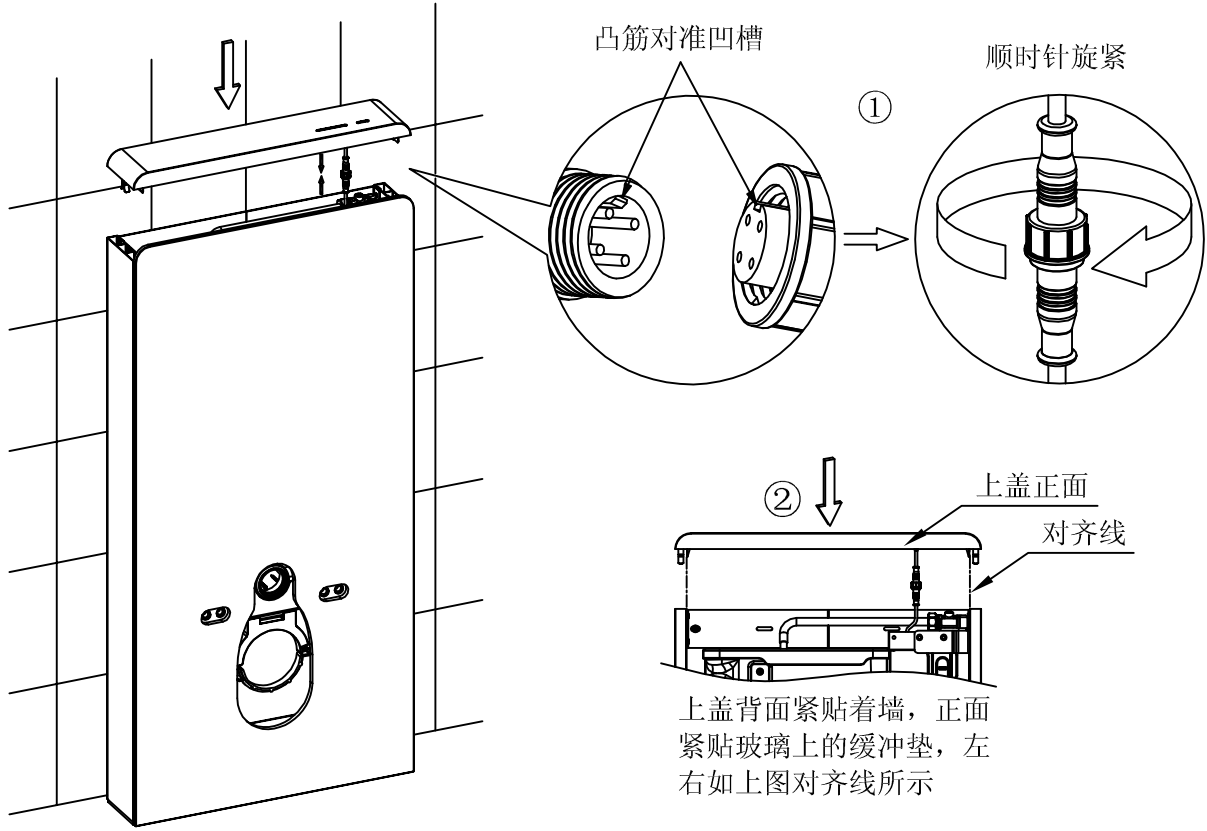

把上盖安装到柜体上

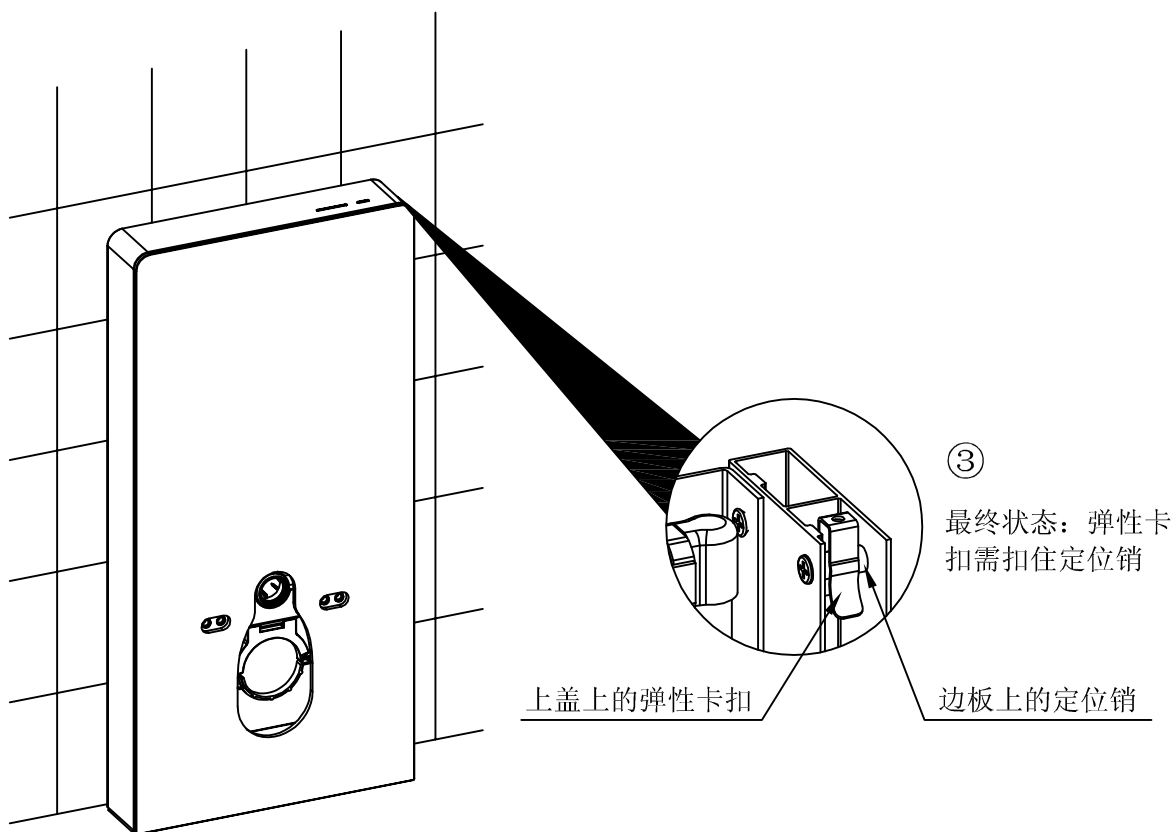

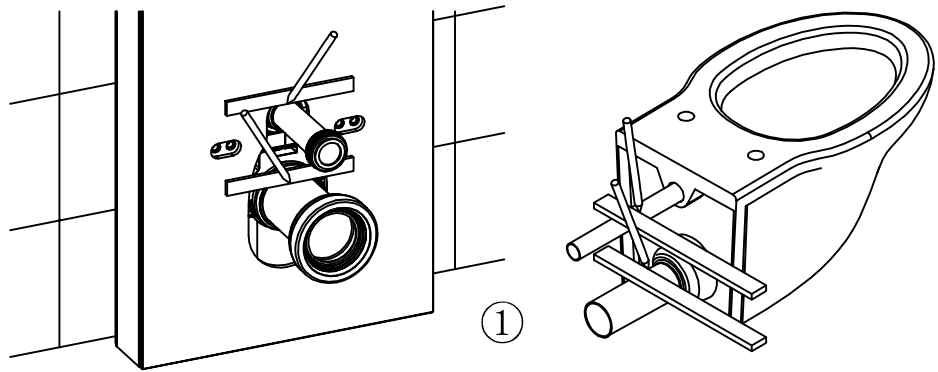
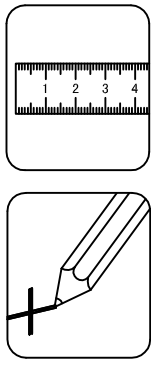

在冲水直管和排水直管上划线

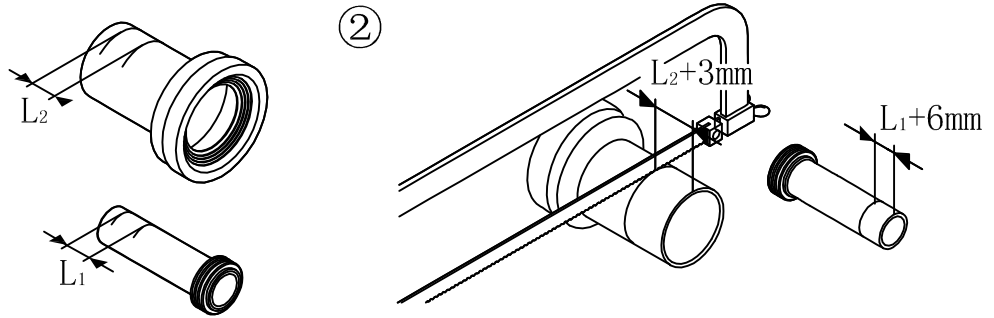
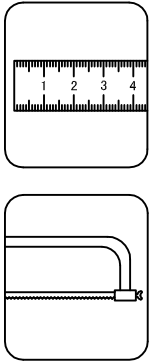

裁剪冲水直管和排水直管
cut the flush pipe and drainage pipe

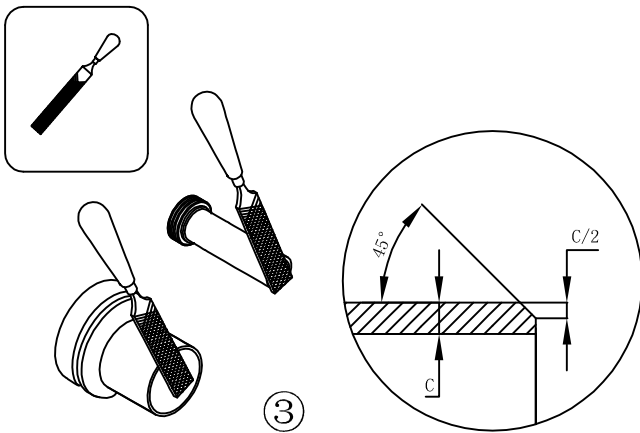

冲水直管和排水直管口部倒角

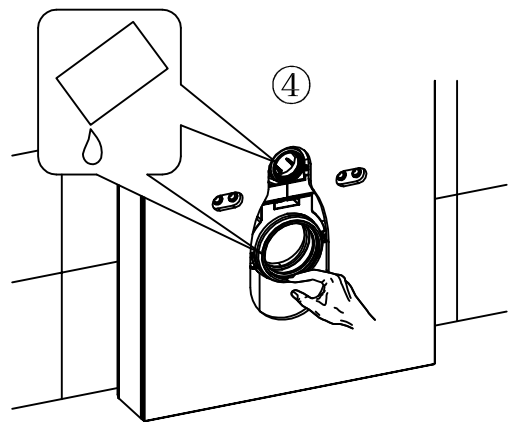

抹硅油

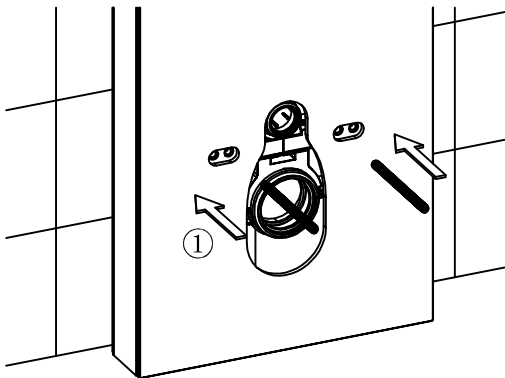
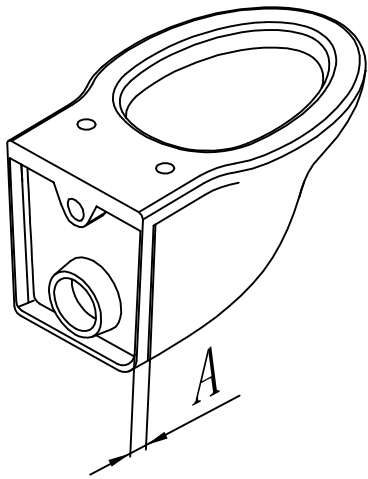

把螺杆安装到机架上
screw the bolts into the
cistern frame

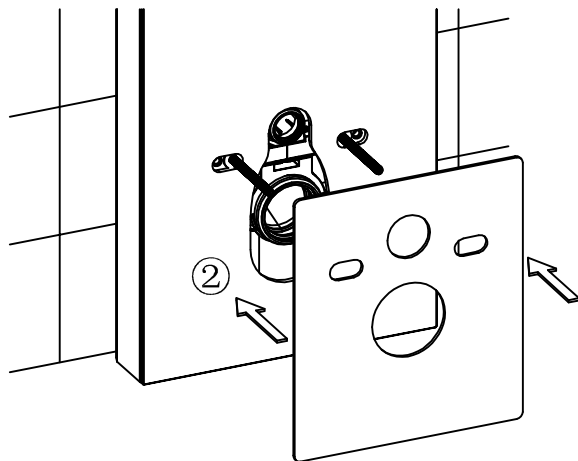
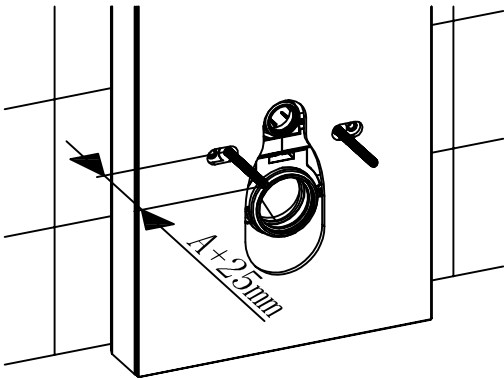

安装马桶缓冲垫
install toilet mat

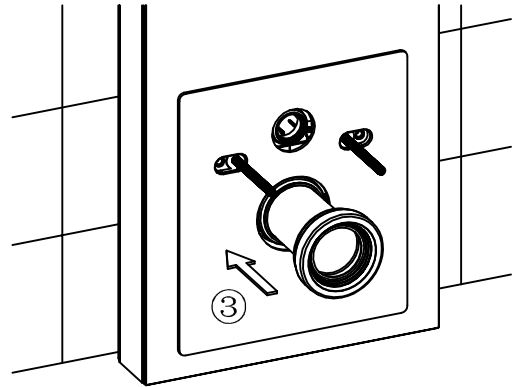

把排水直管安装到机架上
install the flush pipe onto
the cistern

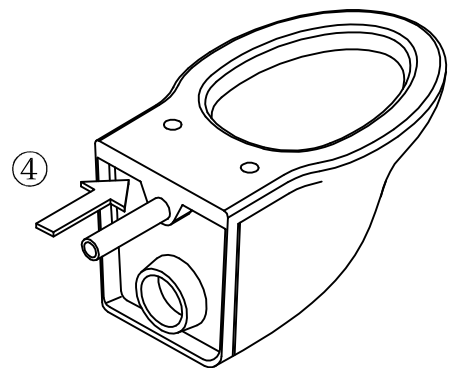

把冲水直管安装到马桶上
install the flush pipe onto
the toilet.

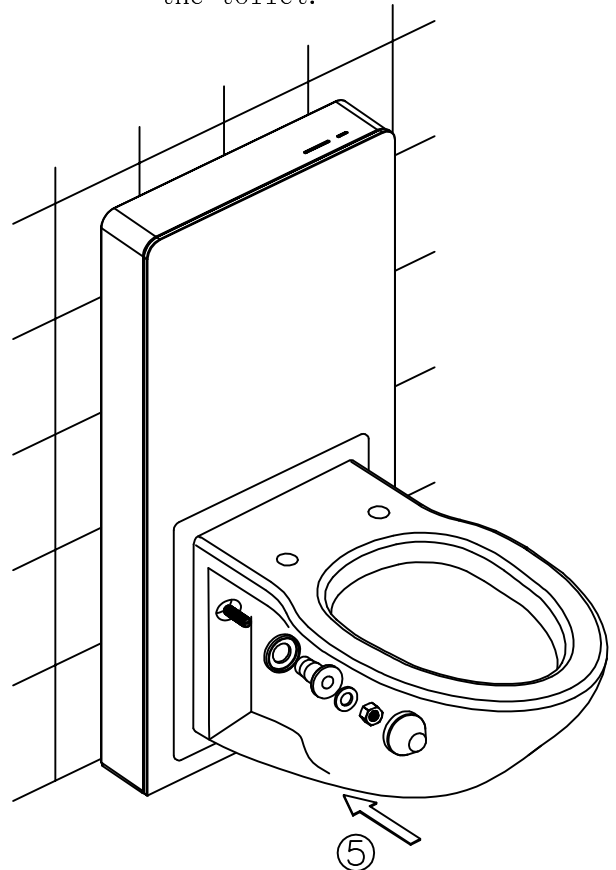

安装马桶
install toilet

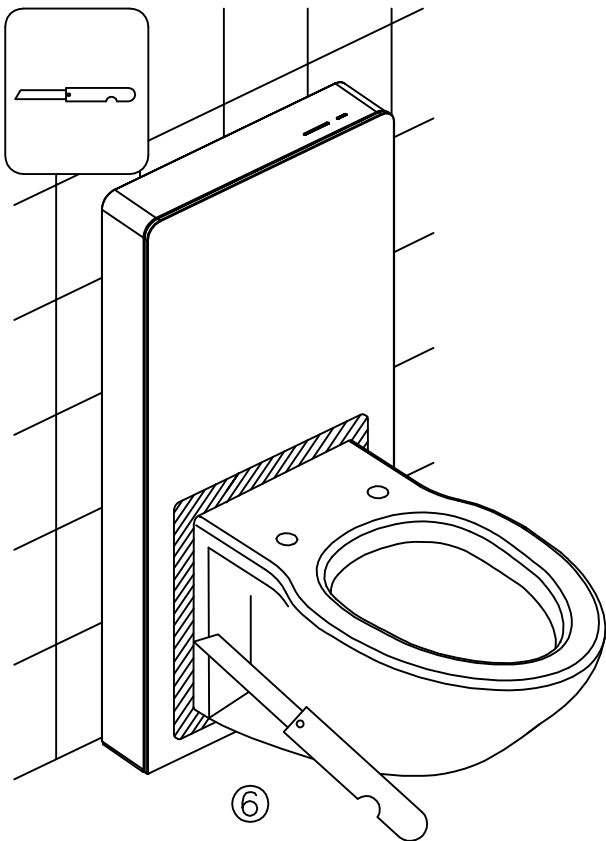

⑥
割除多余的马桶缓冲垫
cut off extra part of the
toilet mat

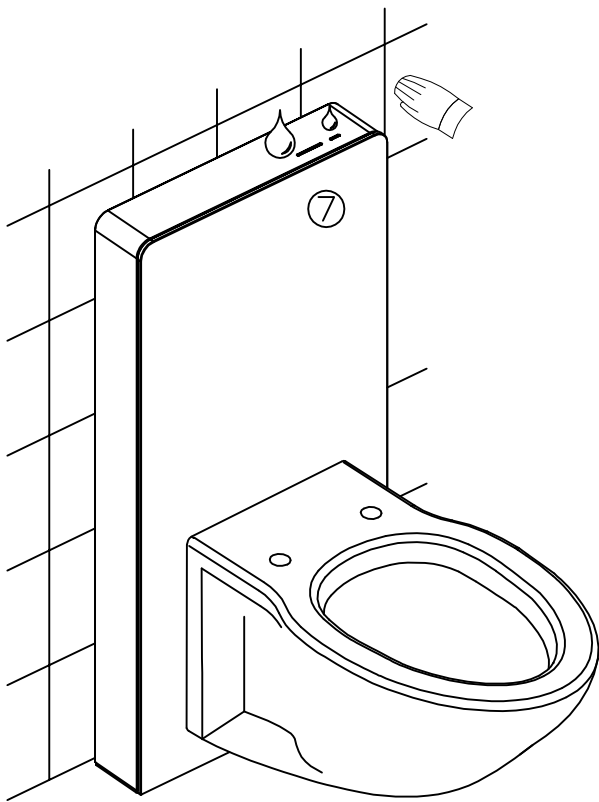

感应区域：距离顶板约50mm内
挥手分别通过全半排感应区域，
测试全半排功能

日常保养与拆装

Maintenance & daily care

1.1 进水阀的拆卸

1.1 inlet valve removal

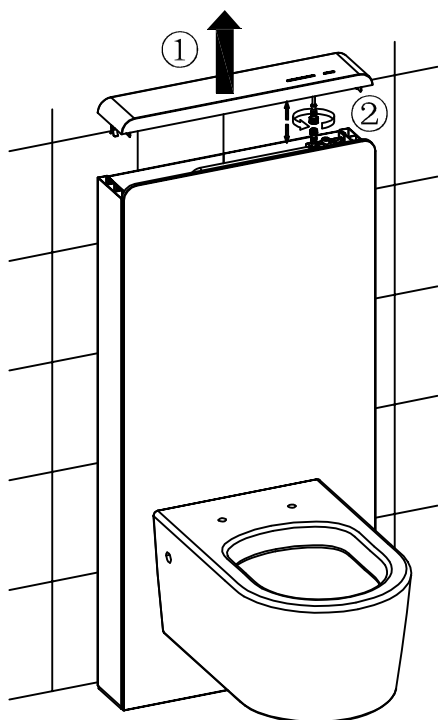

掀开上盖，并旋开公母插头

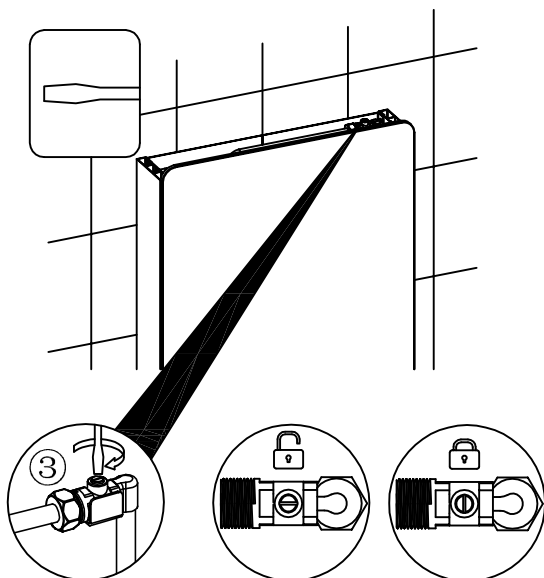

关闭编织管上的阀门
turn off the stop valve on
the flexible hose

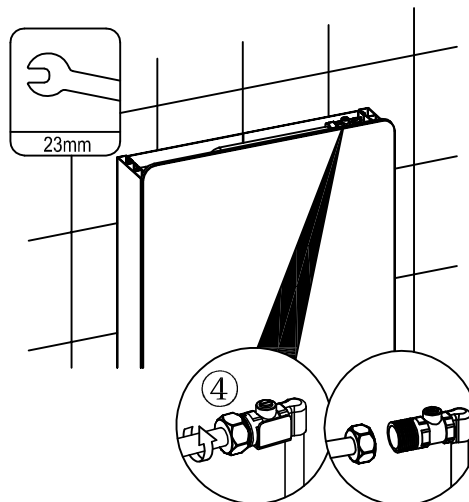

旋开编织管之间的连接
unconnect hose and the valve

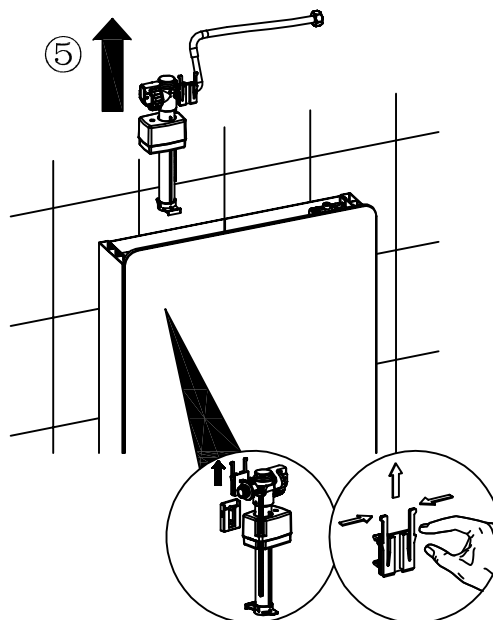

向上拆出进水阀
take off the inlet valve
upwards

1.2 进水阀的调整与清洗
1.2 inlet valve adjustment & clean

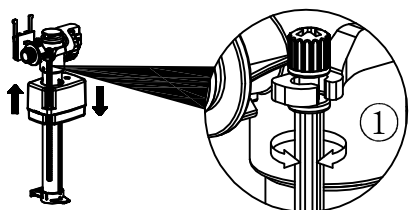

通过旋转进水阀上的螺杆可调节浮桶的高度进而调节水箱的进水量，浮桶上升则进水量增加，反之则进水量减少

adjust the float upwards to increase the inlet volume; or downwards to reduce the volume

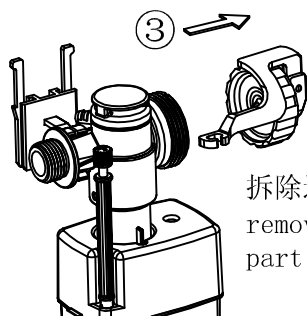
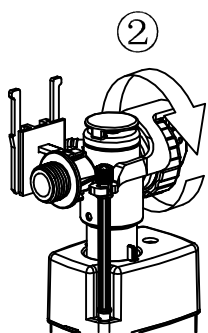

拆除进水阀上的止水组件
remove the water-stopping part

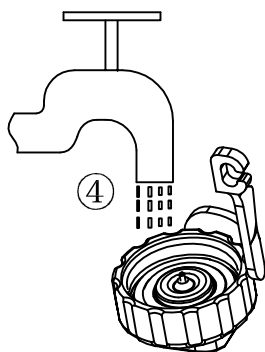

清洗止水组件
wash this removed part

1.3 进水阀的安装
1.3 inlet valve installation

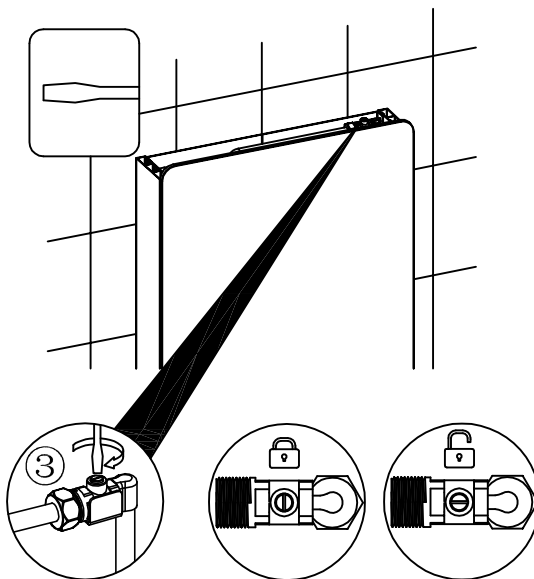
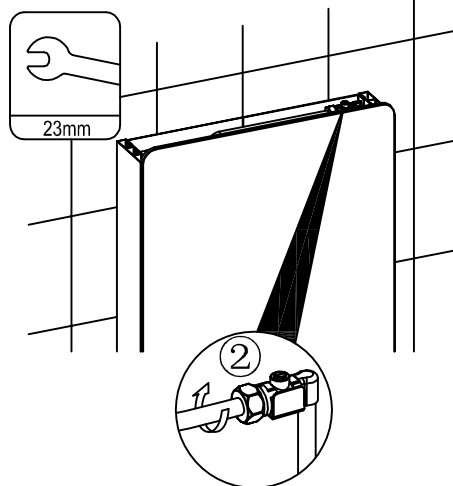
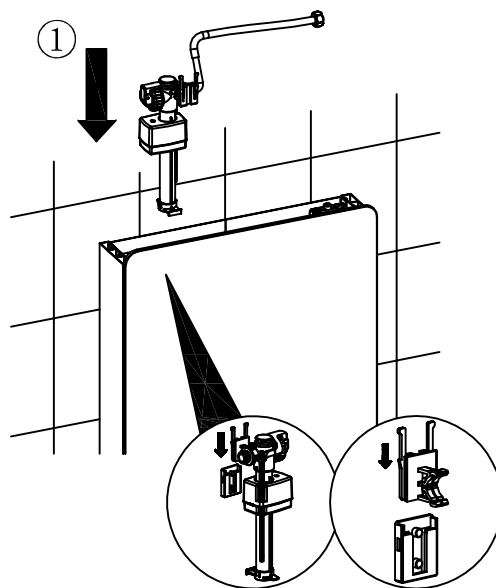

2.1 排水阀的拆卸
2.1 flush valve removal

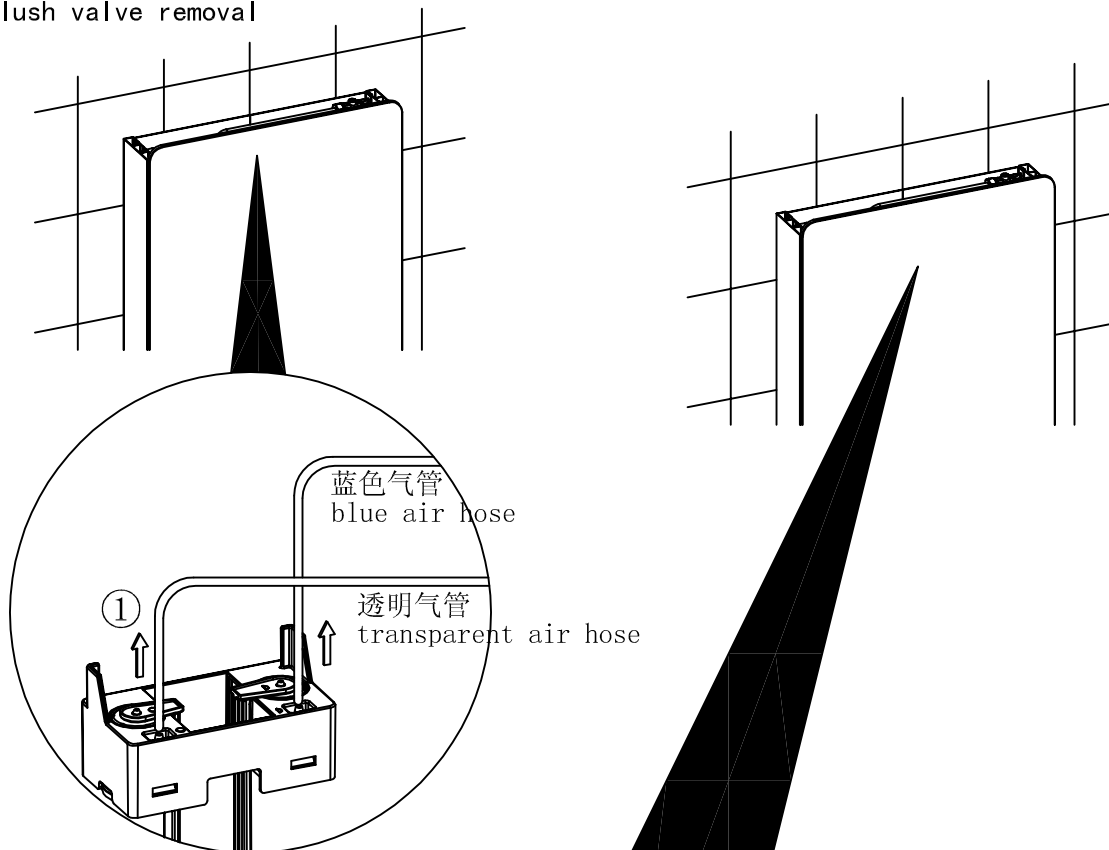

断开气控组件与气管的连接
un-connect the air hoses from
the air hose holes

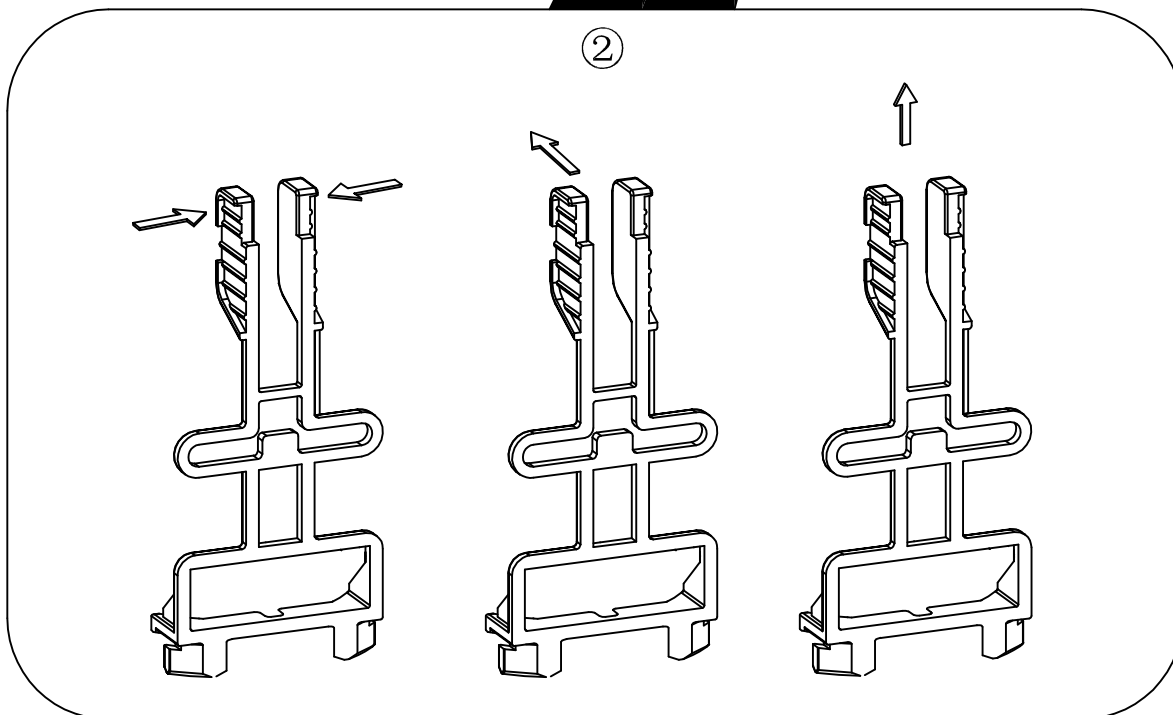

拆除压杆
remove the lever

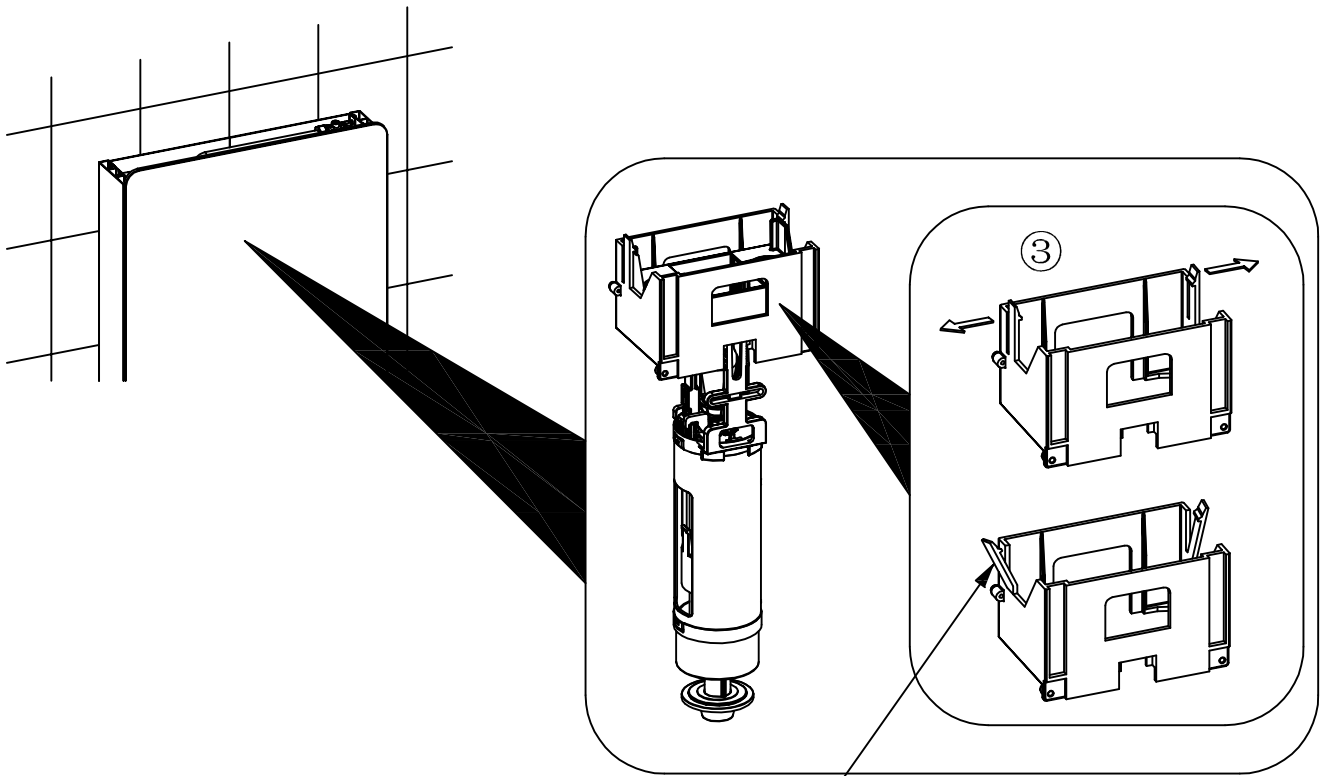

水箱挂板上的卡扣
buckles on the cistern hunger

在撑开水箱挂板上的卡扣的同时，向上提起排水阀
lift upwards the flush valve after opening the buckles on the
cistern hunger

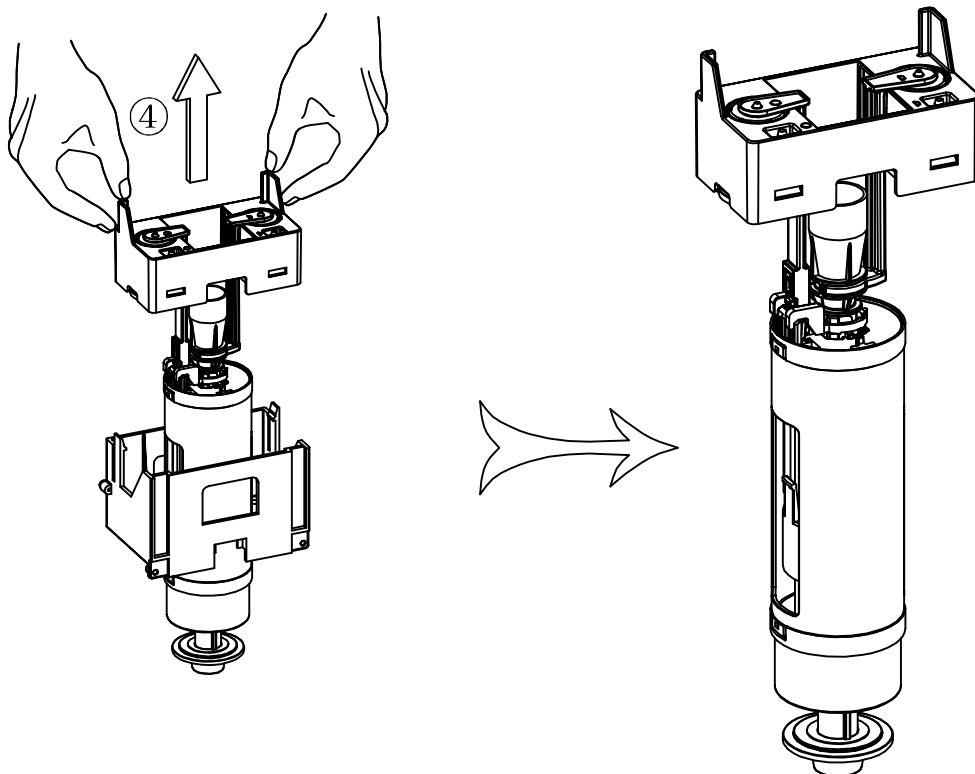

2.2 排水阀的调整与清洗
2.2 flush valve adjustment & clean

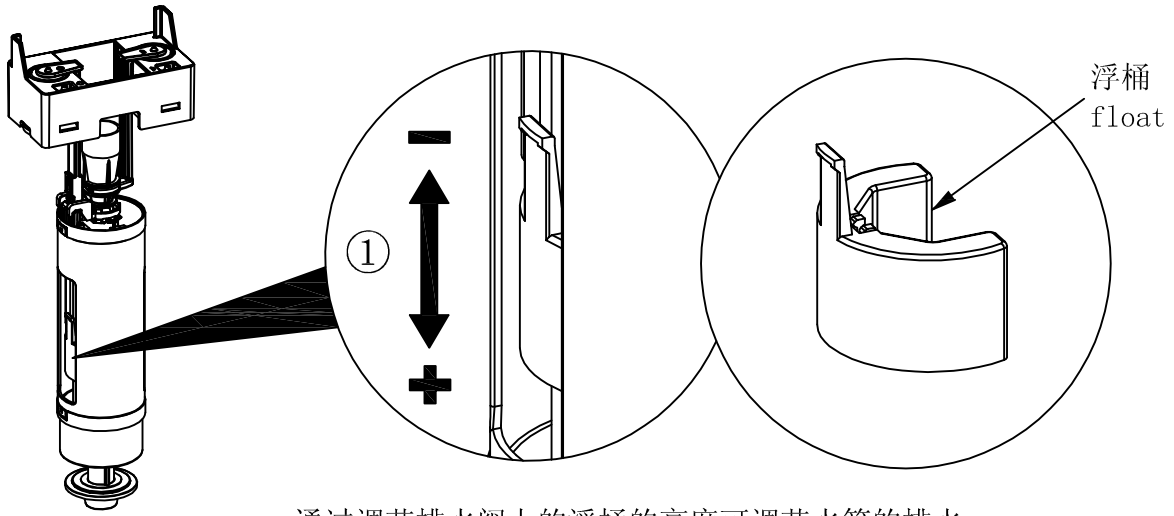

通过调节排水阀上的浮桶的高度可调节水箱的排水量，浮桶上升则排水量减少，反之则排水量增加
adjust the float upwards to reduce the flush volume; or downwards to increase the volume

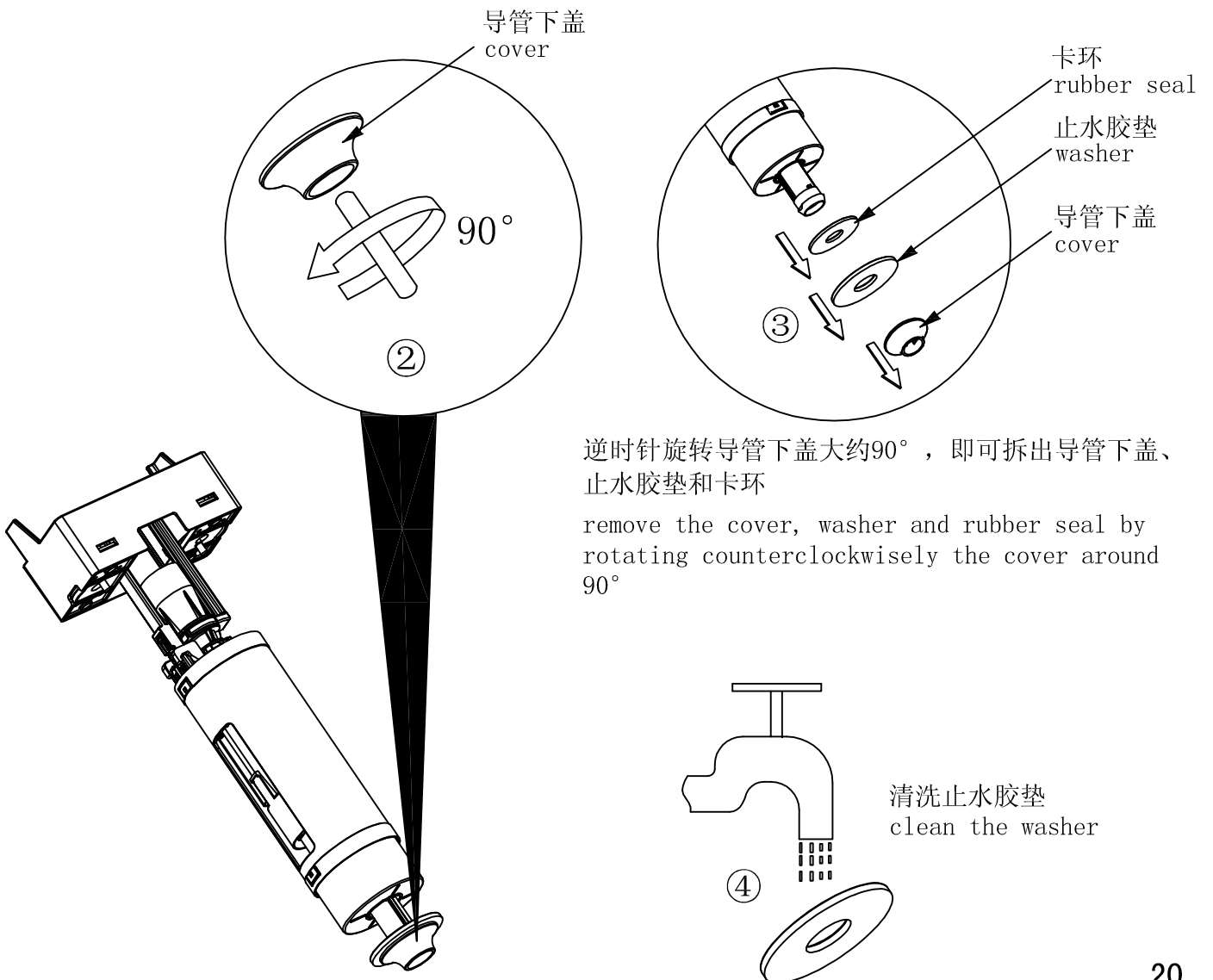

逆时针旋转导管下盖大约90°，即可拆出导管下盖、止水胶垫和卡环
remove the cover, washer and rubber seal by rotating counterclockwisely the cover around 90°

2.3 排水阀的安装
2.3 flush valve installation

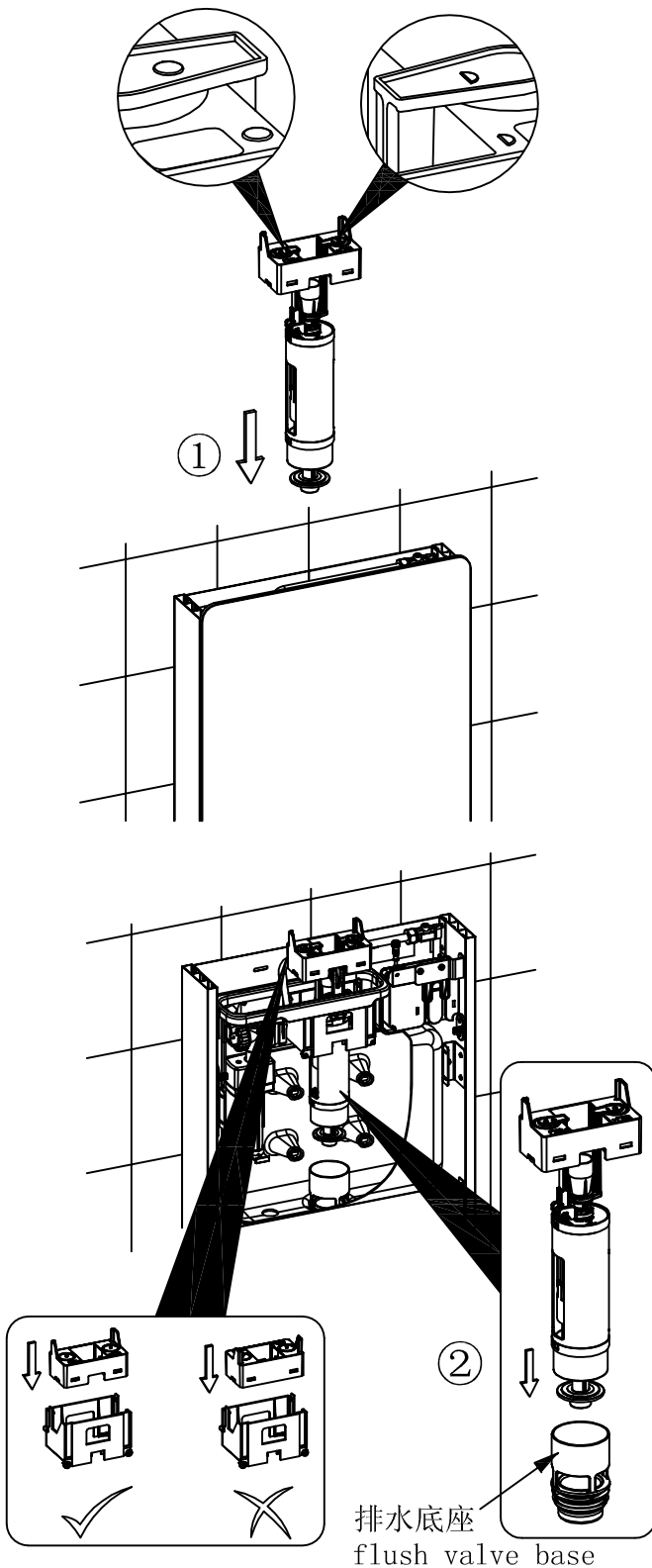

把排水阀向下安装回水箱里(注意：排水阀的底部要对准排水底座；排水阀只有唯一一个正确的安装方向，安装时请按照图示仔细核对)

install the flush valve downwards into the cistern body (Mark: make sure the flush valve bottom is aligned with flush valve base. And please make sure flush valve is installed in the shown direction during installation.)

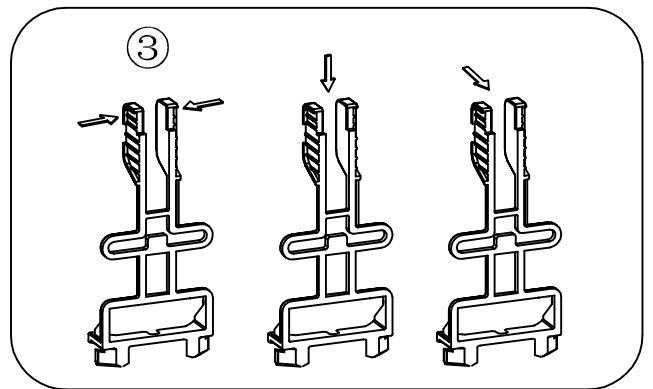
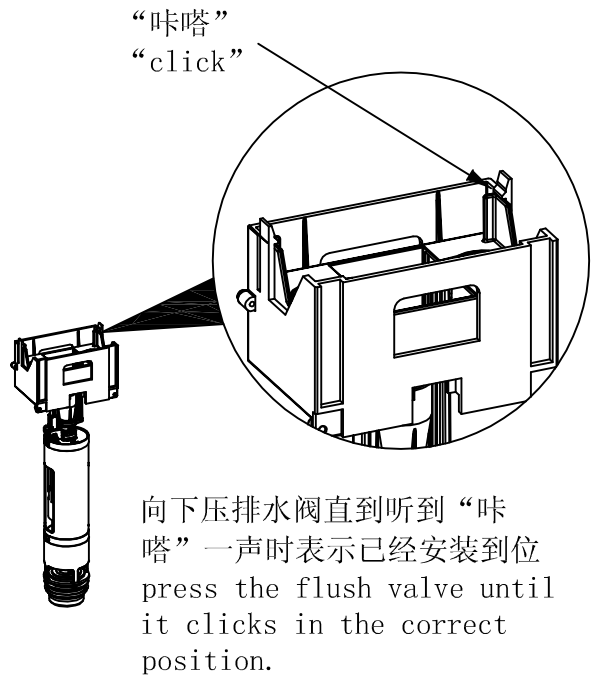

安装压杆
re-install the lever

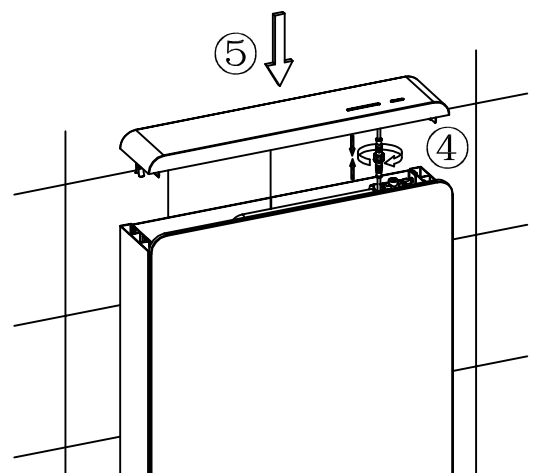

安装上盖
re-install the top glass cover



高宝官网



官方微信

Gobo

深圳市成洁厨卫有限公司

深圳市罗湖区笋岗街道田心社区宝安北路3008号宝能中心C栋8层8A05

客服专线:4008-520-630 www.gobo.com.cn

制造厂商:高宝厨卫(浙江)有限公司

地 址:浙江省金华市磐安工业园月牙路9号